

AVAILABLE FOR RENT OR SALE



www.atsequipment.com

MQ Mikasa MVC82VHW

FORWARD SOIL PLATES

- Reliable engine with Honda GX160 offering easy start-up and low oil shutdown for durability.
- Cyclonic pre-cleaner captures most airborne contaminants for engine protection and extended service life.
- Anti-vibration handle dramatically reduces operator fatigue and increases productivity.
- Solid, high-strength steel base plate for durability.
- Tubular steel roll bar protects engine components and provides central lifting point.
- Sealed belt cover keeps dirt and rocks out extending belt life.
- Open base plate design makes for easier removal of dirt and rock build-up.
- Cog-tooth belt drive enables longer life compared to conventional V-belts.
- Front mounted exciter assembly allows for easy service access.
- Removable, tool-free water tank can easily be refilled to 11.5 quart capacity.



SPECIFICATIONS

Centrifugal Force: 3080 lb
 Exciter Speed: 5600 VPM
 Plate Size: 17.7 x 22.4 in
 Max Forward Speed Per Min.: 72 ft
 Fuel Consumption Per Hour: 0.31 gal
 Water Tank Capacity: 11.5 qt
 Operating Weight: 181 lb
 Shipping Weight: 200 lb

DIMENSIONS & WEIGHTS

A	Length (including handle)
B	Height (without handle)
C	Height (including handle)
D	Plate Length
E	Plate Width

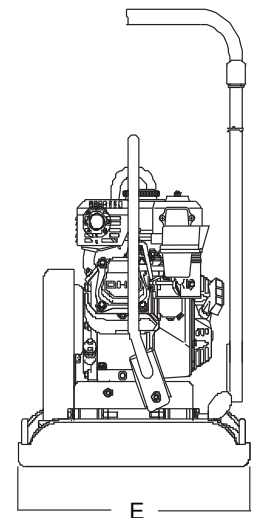
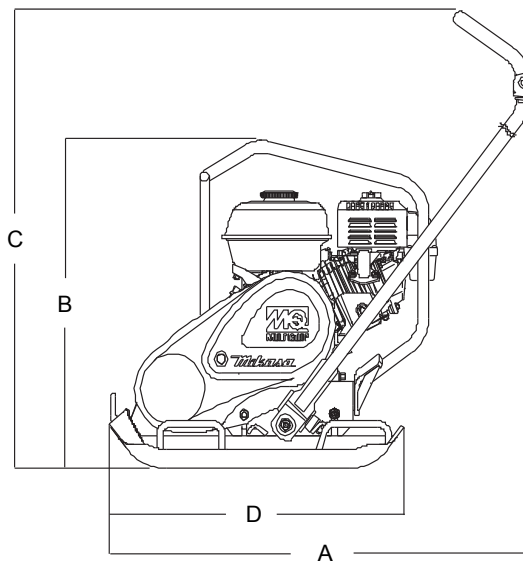

ATS EQUIPMENT INC. Construction Equipment & Supplies Rentals • Sales • Service

BOSTON, MA
(617) 825-3600

AUBURN, MA
(508) 832-8500

REHOBOTH, MA
(508) 379-6200

CANDIA, NH
(603) 483-2100